

Jan. 10, 1956

J. T. McNANEY
CATHODE RAY APPARATUS
Filed Oct. 28, 1952

2,730,708

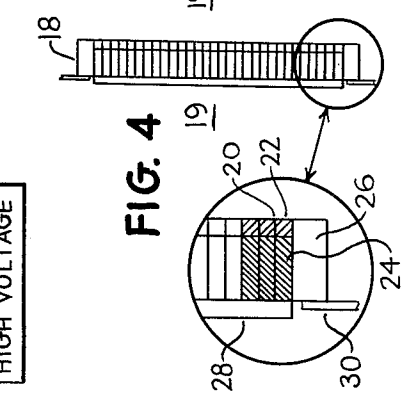
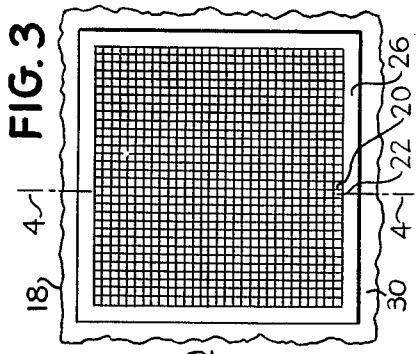
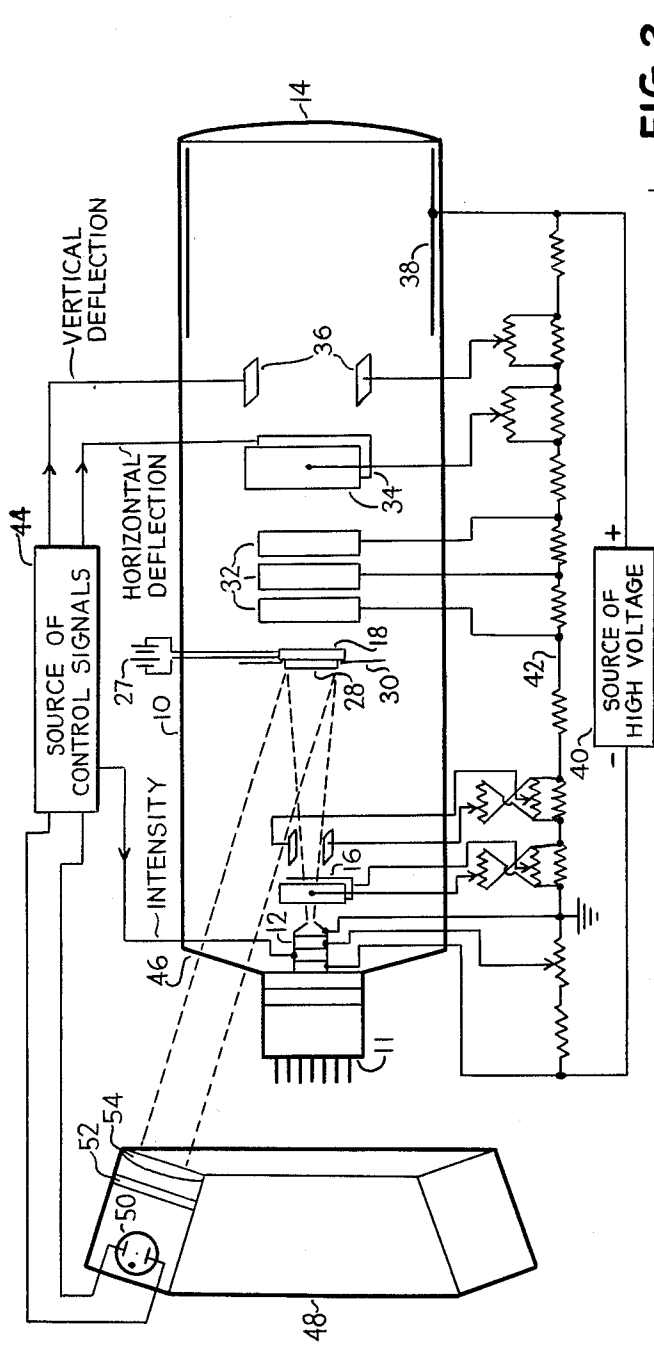

FIG. 1

FIG. 3

FIG. 4

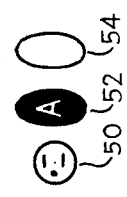

FIG. 2

INVENTOR.
JOSEPH T. McNANEY
BY
Walter J. Jason
ATTORNEY

1

2,730,708

CATHODE RAY APPARATUS

Joseph T. McNaney, San Diego, Calif., assignor, by mesne assignments, to General Dynamics Corporation, a corporation of Delaware

Application October 28, 1952, Serial No. 317,289

12 Claims. (Cl. 340—324)

This invention relates to improved cathode-ray apparatus for selectively displaying images having predetermined shapes, such as characters.

The apparatus of my invention is particularly suitable for displaying information at high speeds, and it may be employed with suitable recording apparatus to provide a printed record of the displayed information. If desired, the apparatus may be arranged to provide a display which is suitable for direct visual observation.

My U. S. Patents Nos. 2,275,017 and 2,283,383 disclose cathode-ray tubes which are suitable for selectively displaying images of characters on the viewing screen of the tube. The cathode-ray tubes disclosed in these patents are of two general types. In one type the beam of electrons in the cathode-ray tube is employed to selectively produce secondary streams of electrons which are projected through character-shaped openings to the viewing screen of the tube. In the other type, the beam of the cathode-ray tube is employed to actuate localized areas of electron-emissive material which are shaped in the form of characters, and the electrons emitted by the electron-emissive material are directed to the viewing screen of the tube. In both types of tubes, the selected characters are displayed at a common location on the screen of the tube, and only one character is displayed at a time.

I have found that cathode-ray apparatus may be arranged so that the intensity and cross-sectional shape of the stream of electrons which is projected onto the screen of the tube is controlled by means of light, and that the stream of electrons can be directed to any part of the screen of the tube after it has been shaped. With such an arrangement, a plurality of characters may be displayed at one time and the characters may be displayed along lines on the screen of the tube if desired.

In accordance with my invention, I provide an evacuated container having a conventional electron gun located at one end and a screen located at the other end. A mosaic of closely spaced thermionic electron emitters is located between the electron gun and the screen, and when selected emitters are actuated they serve to provide electrons in the form of a shaped stream which is projected onto the viewing screen. A member composed of a light-sensitive material is connected to the side of the emitters which is adjacent the gun, and this member serves to selectively provide a conductive path between the individual emitters and the electron beam produced by the gun in accordance with the area of the member which is illuminated with light. Thus, the individual emitters are actuated only when the light-sensitive member provides a conductive path between selected emitters and the electron beam produced by the gun, so that the selected emitters are electrically coupled to the electron beam produced by the gun.

The images which are to be displayed on the screen of the tube, say letters or numbers, are projected as light images on the light-sensitive material which controls the operation of the emitters. Preferably the images are projected through a transparent portion of the evacuated

2

container at the end adjacent the electron gun. Substantially any projection arrangement may be employed; however, I prefer to employ neon lamps as a source of light so that the projected images may be flashed on and off rapidly.

The invention is explained with reference to the drawings, in which:

Fig. 1 illustrates a preferred embodiment of the cathode-ray apparatus of my invention;

Fig. 2 illustrates a suitable image projection arrangement;

Fig. 3 shows a preferred construction of the electron emitters or cathodes as viewed from the screen end of the tube; and

Fig. 4 is a sectional view along line 4—4 of Fig. 3.

The cathode-ray apparatus shown in Fig. 1 employs an evacuated container 10 which is preferably made of glass. A connector 11 is provided for making electrical connections with the elements inside the container. For simplicity, the connections to the various elements are shown schematically. An electron gun 12 of a conventional type is located at one end of the container, and a target or screen 14 is located at the other end. Various types of screens may be employed, the type of screen being determined by the manner in which the displayed information is used. Ordinarily a short-persistence type luminescent material is preferable when the displayed information is to be recorded photographically. When the displayed information is to be viewed directly, a medium-persistence luminescent material is preferable.

A conventional electrostatic deflection system 16 is provided for controlling the electron beam which is produced by the gun 12. Ordinarily the adjustment of the deflection system 16 is allowed to remain fixed once the electron beam has been properly positioned.

A plurality of thermionic cathodes or electron emitters 18 are located along the path of the electron beam and they are located in a plane which is disposed substantially perpendicularly with respect to the path of the electron beam which is produced by the gun 12. The emitters are positioned in the form of a mosaic 19, as shown in Fig. 3, and the individual emitters are electrically insulated from one another by enamel insulation 20. The individual emitters comprise a layer of electron emissive material 22, say an oxide coating, affixed to the end of a conductor 24, as shown in Fig. 4. An electric heater 26 is disposed around the mosaic of emitters for heating them to a suitable temperature. The heater 26 is connected to a source 27 of potential for providing power to the heater. A member 28 composed of a light-sensitive material is connected to the ends of the conductors 24 which face the electron gun. By way of example, the member 28 may be composed of selenium, lead sulfide or cadmium sulfide. The member 28 serves to provide a conductive path between the individual emitters and the electron beam from the gun in accordance with the area of the member which is illuminated with light.

Thus, the member 28 serves as a light-controlled gate between the electron beam produced by the gun and the individual electron emitters 22. The emitters 22 serve to project electrons toward the screen 14 only when they are electrically connected through the member 28 to the beam of electrons produced by the gun 12. Thus, the intensity and cross-sectional shape of the electron stream emitted by the emitters 22 may be controlled by the intensity and shape of light images which are projected onto the member 28.

A solid member 30 which extends around all the sides of the mosaic of emitters serves to intercept the flow of the electrons from the gun which do not impinge upon the member 28. Thus, only the electrons produced by

the emitters 22 are allowed to reach the screen of the tube in the form of a beam.

Three accelerating anodes 32 are provided for accelerating and focussing the shaped electron stream immediately after it is produced by the emitters 22.

A pair of horizontal deflection plates 34, and a pair of vertical deflection plates 36 are provided for directing the stream of electrons toward predetermined locations on the screen of the tube. The spacing between the deflection plates 34, 36 is larger than the corresponding dimensions of the mosaic of emitters so as to provide a pair of uniform electron deflecting fields throughout the area through which the shaped stream of electrons may be projected. A magnetic deflection system may be employed instead of the electrostatic deflection plates if desired.

A conventional intensifier anode 38 is provided adjacent the screen of the tube.

Suitable potentials for the various electrodes of the tube are provided by a source 40 of high voltage and a voltage divider 42.

Signals for controlling the light images, the intensity of the beam of electrons provided by the gun 12, and the horizontal and vertical deflection of the shaped stream of electrons produced by the thermionic emitters are produced by a source 44 of control signals. The source 44 may be manually operated, or it may be automatic and arranged to respond to code signals if desired.

The end of the container which is adjacent the electron gun is provided with an annular transparent portion 46 through which images may be projected in order to control the operation of the tube.

The apparatus for producing the light images comprises an annular member 48 provided with a suitable number of image producing arrangements for controlling the cathode-ray apparatus in the desired manner. In a preferred embodiment of the invention I provide means for producing the images of the letters of the alphabet and the numbers 1 to 9 at spaced intervals around the periphery of the member 48.

Fig. 2 illustrates one arrangement for producing the light images. The source of light is a neon bulb 50 and the light produced thereby is projected through a mask 52 and a lens 54. The mask 52 is provided with a transparent portion having the configuration of the letter or number to be projected onto the control member 28 of the tube. The lens 54 serves to focus the image upon the control member 28.

A separate source of light, mask and lens is employed for each light image to be produced. The respective sources of light are selected and controlled by the source 44.

In operation, the source 44 of control signals energizes the neon lamp associated with the letter or number to be displayed, and a gating signal is applied to the control grid of the electron gun 12 each time that a light image is projected into the tube. Simultaneously, potentials are applied to the horizontal and vertical deflection electrodes of the tube to cause the shaped electron stream to impinge upon the desired location on the screen of the tube. If the source 44 of control signals is arranged to function automatically in response to code signals, information may be displayed on the screen of the tube at a high speed, say of the order of 10,000 characters per second. As mentioned hereinbefore, mask 52 may accommodate a single letter, numeral, or symbol, however, it should be understood that the mask is not limited thereto. Any number of letter, numeral, or symbol shaped transparent portions may be provided in the mask 52. Hence, when a control signal produced by source 44 energizes the particular mask 52, all character elements established therein are projected upon the control member 28 of the tube and then registered on the screen 14. Where a plurality of character shaped configurations are provided in mask 52, these may create a code, a word, a phrase, a complete sentence, or an entire paragraph,

thus a single control signal from source 44 may control the display of an entire screen of information depending upon the pattern of permeable areas in mask 52. However, it should be understood that a single control signal developed by source 44 causes the contents of a single mask 52 to be projected upon control member 28, and successive code signals energize successive masks 52 and the contents of each is serially displayed upon the screen 14. For example, if each mask 52 contains a word, then words will be sequentially displayed upon screen 14 as successive control signals are produced by source 44, but if each mask 52 contains but a single letter, then single letters will be sequentially displayed upon the screen 14.

Information may be displayed on the screen of the tube at the rate of 10,000 characters each second, and as mentioned hereinbefore suitable recording apparatus may be employed with the tube to provide a printed record of the displayed information. Generally, where utilization of the speed capacity of the tube is desired, recording apparatus will be used, but the inherent speed of the device may also serve in visual reading of the information displayed on the screen to produce "flicker-free" displays. For example, if the tube is producing characters or symbols at the rate of 10,000 each second, then, 500 different characters can be repetitively displayed 20 times each second to produce an apparently continuous and steady display of the 500 characters without variation.

Although the type of tube herein disclosed is capable of producing extremely high information rates of display which may be utilized in many ways, this tube may also be utilized effectively for very low display rates as well.

I claim:

1. Cathode-ray apparatus comprising an evacuated container, an electron gun located at one end of the container for projecting an electron beam longitudinally along the container, a screen located at the other end of the container, thermionic electron emissive means located along the path of said electron beam for projecting electrons toward the screen, and means for controlling the intensity and cross-sectional shape of the electron stream produced by the electron emissive means, said controlling means including means located between the electron emissive means and the electron gun.

2. Cathode-ray apparatus comprising an evacuated container, a source of electrons for projecting an electron beam longitudinally along the container, a screen located at one end of the container, thermionic electron emissive means located along the path of said electron beam for projecting electrons toward the screen, means for controlling the intensity and cross-sectional shape of the electron stream produced by the electron emissive means, said controlling means including means located between the electron emissive means and said source, at least one accelerating electrode located between the electron emissive means and the screen, and deflection means located between the electron emissive means and the screen for directing the electrons toward predetermined locations on the screen.

3. Cathode-ray apparatus comprising an evacuated container, a source of electrons located in the container for projecting a beam of electrons longitudinally along the container, a screen located at one end of the container, thermionic electron emissive means located between the source of electrons and the screen for projecting electrons toward the screen, and light-sensitive means connected to the side of the emissive means which faces said source of electrons for providing a conductive path between the emissive means and the electron beam from said source when the light-sensitive means is illuminated.

4. In an evacuated container having a screen at one end and a source of electrons at the other end for projecting an electron beam longitudinally along the container, a plurality of closely spaced thermionic emitters located intermediate the source of electrons and the screen

5

for projecting electrons toward the screen, and light-sensitive means connected to the side of the emitters which faces said source of electrons for providing a conductive path between selected emitters and the electron beam from said source in accordance with the area of said light-sensitive means which is illuminated with light.

5. Cathode-ray apparatus comprising an evacuated container, an electron gun located at one end of the container for projecting an electron beam longitudinally along the container, a plurality of thermionic electron emitters located along the path of the electron beam, the emitters being electrically insulated from one another and located in a plane which is disposed substantially perpendicularly with respect to the path of the electron beam, and light-sensitive means connected to the side of the emitters which is adjacent said electron gun for selectively providing a conductive path between the individual emitters and the electron beam from said electron gun in accordance with the area of said light-sensitive means which is illuminated with light.

6. Cathode-ray apparatus comprising an evacuated container, an electron gun located at one end of the container for projecting a beam of electrons longitudinally along the container, a screen located at the other end of the container, a plurality of thermionic cathodes located between the electron gun and the screen and located in a plane which is disposed substantially perpendicularly with respect to the axis of the container, and light-sensitive means located between the cathodes and the electron gun for providing a conductive path between the individual cathodes and the beam of electrons from the gun in accordance with the area of said light-sensitive means which is illuminated with light, said container having a transparent portion located in the end adjacent the electron gun for admitting light to said light-sensitive means.

7. The apparatus of claim 6 further including means located outside the evacuated container for projecting images of characters through the transparent portion of the container and onto the light-sensitive means.

8. Cathode-ray apparatus comprising an evacuated container, an electron gun located at one end of the container for projecting an electron beam longitudinally along the container, a plurality of thermionic electron emitters located along the path of the electron beam, the emitters being electrically insulated from one another and located in a plane which is disposed substantially perpendicularly with respect to the path of the electron beam, means for heating said thermionic emitters, and a member composed of a light-sensitive material connected to the side of the emitters which is adjacent said electron gun for selectively providing a conductive path between the individual emitters and the electron beam for said electron gun in accordance with the area of said member which is illuminated with light.

9. In combination, an evacuated container having a screen at one end and a source of electrons at the other end for projecting an electron beam longitudinally along the container, a plurality of closely spaced thermionic emitters located intermediate the source of electrons and the screen for projecting electrons toward the screen, the emitters being electrically insulated from one another and located in a plane which is disposed substantially perpendicularly with respect to the longitudinal axis of the container, light-sensitive means connected to the side of the emitters which faces said source of electrons for providing a conductive path between selected emitters and the electron beam from said source in accordance with the area of said light-sensitive means which is illuminated, means for projecting predetermined images on the light-sensitive means, and deflection means located between the emitters

6

and the screen for directing the emitted electrons toward predetermined locations on the screen.

10. Cathode-ray apparatus comprising an evacuated container, a source of electrons located in the container for projecting a beam of electrons longitudinally along the container, a screen located at one end of the container, thermionic electron emissive means located between the source of electrons and the screen for projecting electrons toward the screen, light-sensitive means connected to the side of the emissive means which faces said source of electrons for providing a conductive path between the emissive means and the electron beam from said source when the light-sensitive means is illuminated, at least one accelerating electrode located between the electron emissive means and the screen, and deflection means located between the electron emissive means and the screen for directing the electrons toward predetermined locations on the screen.

11. Cathode-ray apparatus comprising an evacuated container, an electron gun located at one end of the container for projecting an electron beam longitudinally along the container, a screen located at the other end of the container, a plurality of closely spaced thermionic emitters located between the electron gun and the screen for projecting electrons toward the screen, the emitters being electrically insulated from one another and located in a plane which is disposed substantially perpendicularly with respect to the longitudinal axis of the container, light-sensitive means connected to the side of the emitters which is adjacent the source of electrons for providing a conductive path between selected emitters and the electron beam from the electron gun in accordance with the area of the light-sensitive means which is illuminated, and means for projecting selected images on the light-sensitive means to illuminate predetermined areas thereof.

12. Cathode-ray apparatus comprising an evacuated container, an electron gun located at one end of the container for projecting an electron beam longitudinally along the container, a screen located at the other end of the container, a plurality of closely spaced thermionic emitters located between the electron gun and the screen for projecting electrons toward the screen, the emitters being electrically insulated from one another and located in a plane which is disposed substantially perpendicularly with respect to the longitudinal axis of the container, light-sensitive means connected to the side of the emitters which is adjacent the source of electrons for providing a conductive path between selected emitters and the electron beam from the electron gun in accordance with the area of the light-sensitive means which is illuminated, at least one accelerating electrode located between the emitters and the screen, and means located between the emitters and the screen for providing a pair of electron-deflecting fields for directing the electrons produced by the emitters toward predetermined locations on the screen, each field of said pair extending across an area in the evacuated container which is larger than the area occupied by said plurality of emitters.

References Cited in the file of this patent

UNITED STATES PATENTS

2,099,980	Iams -----	Nov. 23, 1937
2,150,168	Ives -----	Mar. 14, 1939
2,203,334	Labin -----	June 4, 1940
2,275,017	McNaney -----	Mar. 3, 1942
2,277,246	McGee et al. -----	Mar. 24, 1942
2,283,383	McNaney -----	May 19, 1942
2,538,065	Wallace -----	Jan. 16, 1951